

No more unpleasant odors

No more unhygienic disposal

No more inconvenient cleaning

No more compromises on toilet comfort

Sanitary comfort beyond campsite limits. How it works.

The toilet automatically seals waste securely in bags in accordance with medical hygiene standards and collects them in a space-saving manner. The bags can easily be disposed of in residual waste. The Clesana C1 requires no sanitary additives or water and is completely odor-proof and hygienic thanks to its high-barrier foil liner. This is ensured by a special thermo-pressure process and a patented sealing mechanism.

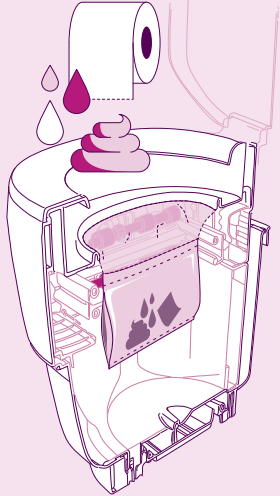

It's that easy!
How it works, explained in 3 minutes.



Safe. Sanitary. Comfortable.



clesana.com

 clesana®



Clesana C1

The Sealing Toilet.



SWISS
MADE

The Clesana C1.

Trusted safety, ultimate comfort.



Maximum impermeability, completely odorless

Thanks to high-barrier film and a unique patented sealing mechanism. Scientifically proven!



Independent and flexible

Total freedom from waste disposal stations and campsite facilities. Easy and discreet disposal in general waste.



Maximum convenience

Comfortable seat, perfect height, and effortless, intuitive handling.



Clinically tested

Developed in the healthcare sector to achieve the highest hygiene standard among portable toilets.



Zero maintenance

No winterization or cleaning required.



Eco-friendly and resource-efficient

No water, no chemicals, no (sanitary) additives necessary.



Highly versatile

Disposal of wet wipes, female hygiene products, food waste, etc.



Swiss Made

Highest quality and precision from Switzerland.

Easy retrofitting.

The Clesana C1 is compatible with the most common cassette toilets in terms of layout and can simply be retrofitted based on these toilet systems. For complex electrical installations, the Clesana power management offers a simple solution.

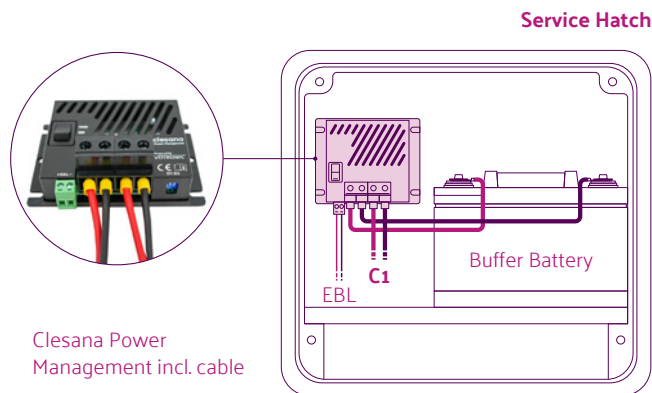

Clesana Power Management incl. cable

More autonomy.

The optional Clesana power management system makes installing the Clesana C1 even easier – and your camper significantly more autonomous. Existing wiring in the vehicle can be reused, eliminating the need for costly new installations. In combination with a small buffer battery, the smart add-on module supplies power exactly when you need it – and automatically recharges the buffer battery. Even if the supply battery fails, your toilet will continue to function reliably.

Technical specifications

Nominal voltage	12 V
Max. current consumption (short term)	22 A
Power consumption standby mode	0.28 W
Energy consumption sealing process	0.55 Wh
Energy consumption separation process	1.7 Wh

Efficient energy use: Up to 100 bags can be sealed with the 10 Ah capacity of a LiFePO4 battery.



Sustainability and hygienic safety without compromise.

The organic Clesana high-barrier film made from sustainable materials was developed specifically for medical requirements. It provides reliable protection against the escape of odors and liquids. For a clean, odor-free, and eco-friendly disposal. No water. No chemicals.

The TÜV-certified organic high-barrier film consists mainly of plant-based materials and combines a high barrier performance with responsible use of resources.

Scientifically proven: Clesana high-barrier films offer the best protection.

The excellent barrier effect has been confirmed by the Fraunhofer Institute IVV. The test report proves that the film used by Clesana offers significantly superior protection compared to commercially available alternatives.

To the article

Fraunhofer IVV tests film bag from Clesana

